

Features and Benefits

- Two channel quadrature output
- Industry standard 7272 line driver output
- RS-422 compatible output
- 5V output standard; 24V output available
- Options up to 5000 pulses per channel per revolution
- Higher pulse counts available
- Operates in harsh environments
- No moving parts provide robust, trouble-free operation

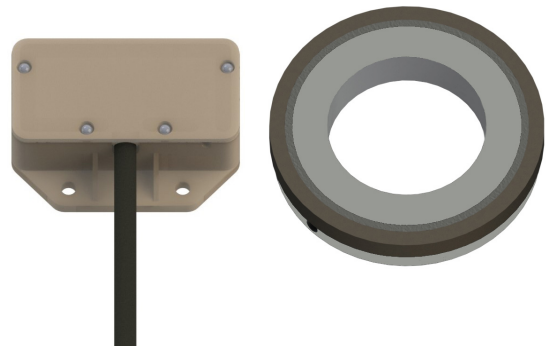

Kit - Encoder with Target Magnet

Resolution - Pulses Per Revolution

1 PPR = 4 Counts

Table 1.1

Output PPR - Decade	Maximum Shaft Speed, RPM
50	15,000
100	15,000
200	15,000
400	15,000
500	4,800
640	3,750
800	15,000
1000	4,800
1250	7,800
1600	12,000
2000	4,800
2500	7,800
3200	6,000
4000	4,800
5000	3,750

Output PPR - Binary	Maximum Shaft Speed, RPM
64	15,000
128	15,000
256	15,000
512	15,000
1024	15,000
2048	9,500
4096	4,500

Contact sales@phoenixamerica.com for higher shaft speeds.

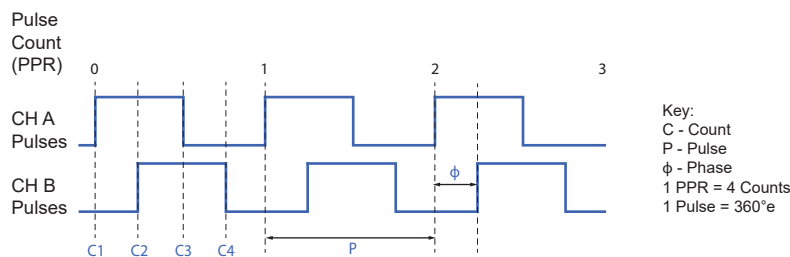

Electrical Circuit

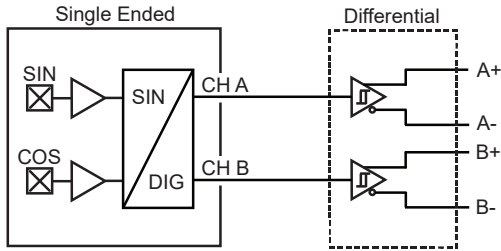

Absolute Maximum Ratings

Table 2.1

Characteristic	Symbol	Rating for 5V	Rating for 6V to 25V	Units
Forward Supply Voltage	V_{CC}	6	28	V
Reverse Supply Voltage	V_{RCC}	-0.3	-20	V
Storage Temperature	T_S	150	150	°C
ESD (HMB, 100pF/1.5Kohm)		4	4	kV

Specifications - 5V Supply

Table 2.2

Characteristic	Symbol	Test Conditions	Min.	Typ.	Max.	Unit
Supply Voltage	V_{CC}	Operating, $T_J < 165\text{ °C}$	4.75	5	5.5	V
Supply Current	I_{CC}	$V_{CC} = 12V$	-	32	50	mA
Operating Temperature	T_A		-40	-	125	°C
Duty Cycle	-	$V_{CC} = 5V, T = 25\text{ °C}$	45	50	55	%
Phase	-	$V_{CC} = 5V, T = 25\text{ °C}$	80	90	100	°e

Specifications - 24V Supply

Table 2.3

Characteristic	Symbol	Test Conditions	Min.	Typ.	Max.	Unit
Supply Voltage	V_{CC}	Operating, $T_J < 165\text{ °C}$	7	12	24	V
Supply Current	I_{CC}	$V_{CC} = 12V$	-	40	65	mA
Operating Temperature	T_A		-40	-	125	°C
Duty Cycle	-	$V_{CC} = 12V, T = 25\text{ °C}$	45	50	55	%
Phase	-	$V_{CC} = 12V, T = 25\text{ °C}$	80	90	100	°e

Output Waveforms

Single Ended

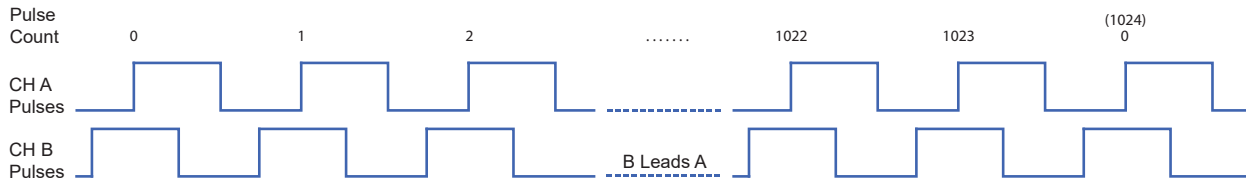
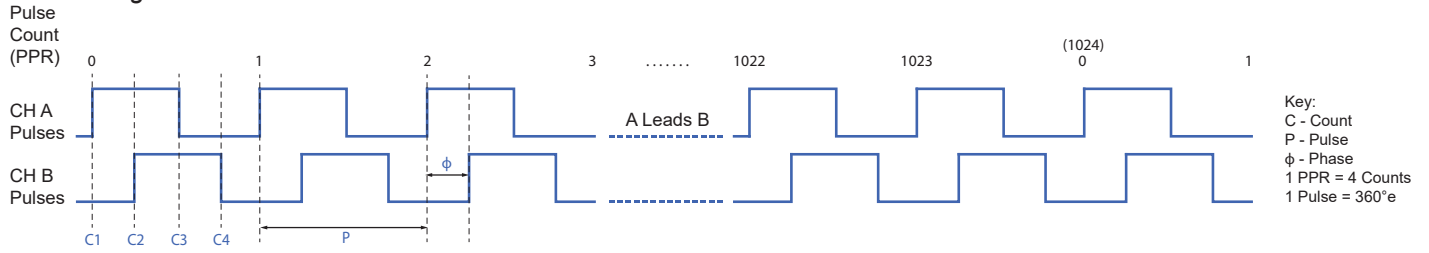

Differential

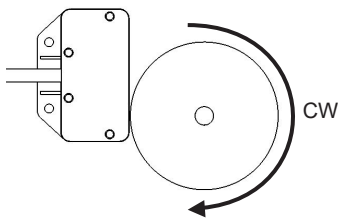
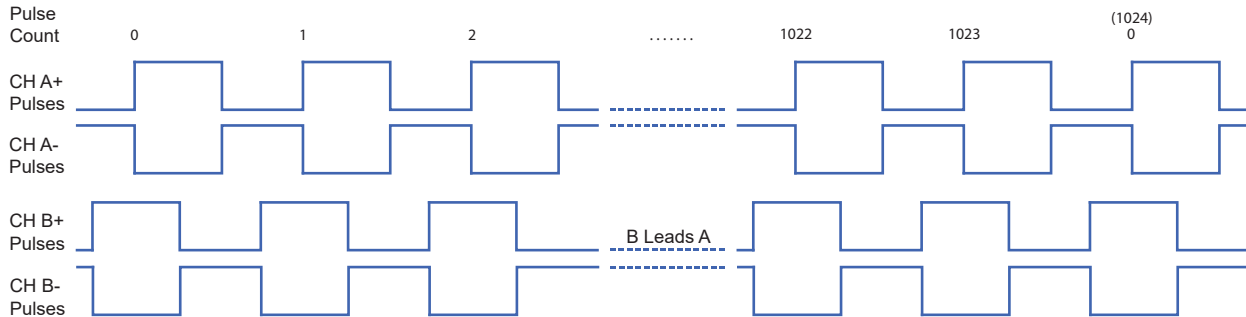
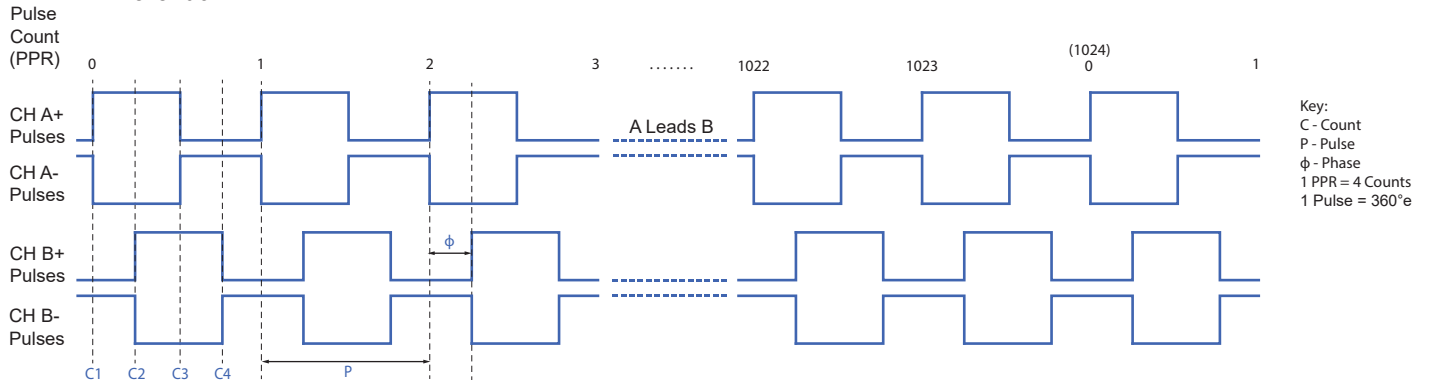

Channel A leads Channel B for clockwise shaft rotation (shaft rotation is defined when looking at the encoder mounting surface).

Encoder Physical Outline

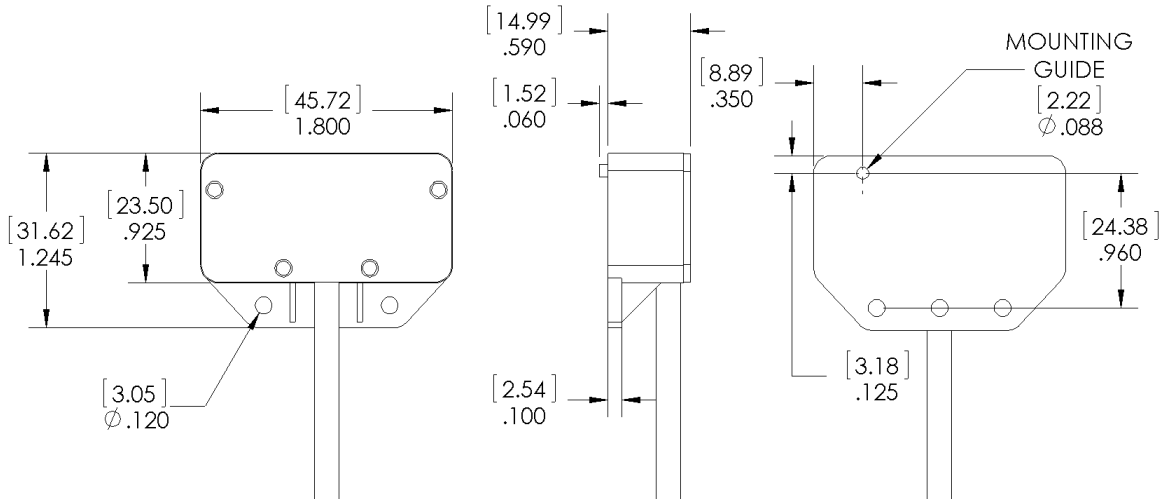

Encoder Mounting Guidelines

- Air gap between magnet rotor and encoder housing should be set to the minimum that can be achieved, taking into account radial play and mounting tolerances. 0.010" to 0.020" is a good target. Air gaps up to 0.040" are acceptable under good conditions.
- The centerline of the magnet rotor should be located 0.220" above the mounting surface of the encoder.
- The encoder and rotor should be mounted perpendicular to the shaft the rotor is mounted on.
- Locating plate is suggested on motor to ensure proper alignment. See sample mounting template below.

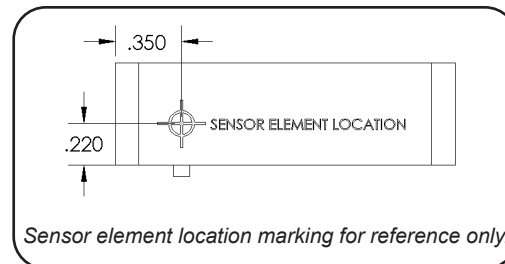
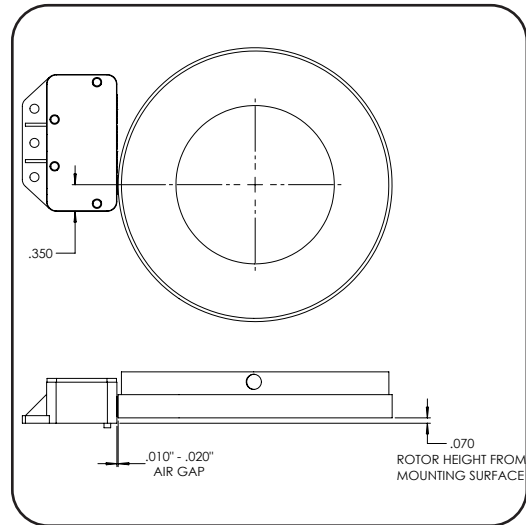
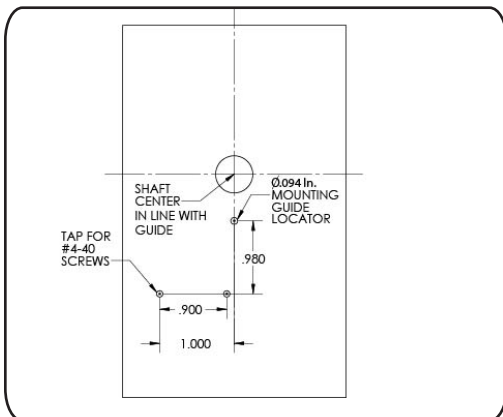

Images show two inch magnet rotor, but alignment targets hold true for all sizes.

Target Rotor Physical Outline - Aluminum Hub (Mounting Style B)

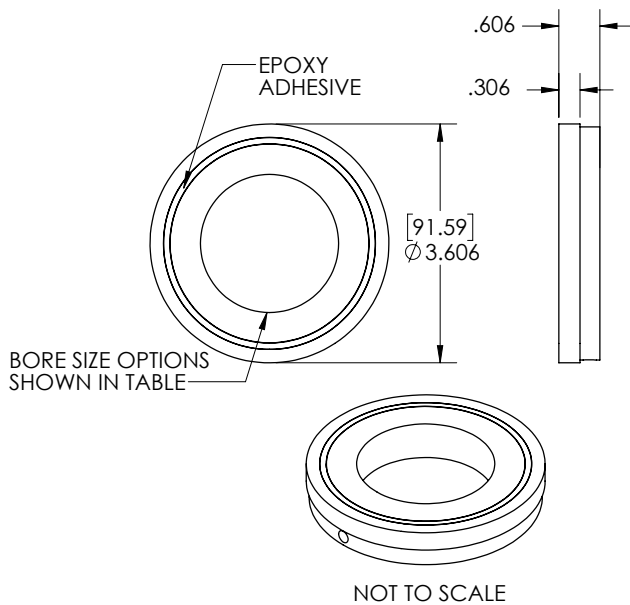

Table 3.1

	Motor Shaft OD Size (nominal)	NEMA Guide Shaft Tolerance	Magnet Bore MIN. (inch)	Magnet Bore MAX. (inch)
1000	1 in (1.0000")	+0.0000"/-0.0005"	1.0009	1.0020
1125	1 1/8 in (1.1250")		1.1259	1.1270
1182	30 mm (1.1820")		1.1829	1.1840
1375	1 3/8 in (1.3750")		1.3759	1.3770
1500	1 1/2 in (1.5000")		1.5009	1.5020
1625	1 5/8 in (1.6250")		1.6259	1.6270
1875	1 7/8 in (1.8750")		1.8759	1.8770
2000	2 in (2.0000")		2.0009	2.0020
2125	2 1/8 in (2.1250")		2.1259	2.1270
2250	2 1/4 in (2.2500")		2.2509	2.2520
2375	2 3/8 in (2.3750")		2.3759	2.3770
2500	2 1/2 in (2.5000")		2.5009	2.5020
2750	2 3/4 in (2.7500")		2.7509	2.7520

*Other bore sizes available upon request.
Contact sales@phoenixamerica.com.*

Target Rotor Mounting Guidelines - Aluminum Hub (Mounting Style B)

- Proper alignment of the target rotor to the encoder sensing element is critical for optimal encoder performance. Insure that the rotor is mounted to the specified height using one of the options shown in the diagram below.
- A machined step on the motor shaft provides a quick and repeatable method for positioning the target rotor. Spacers or other fixturing should be used to properly position the rotor if no mechanical locating features are on the shaft.
- While the hub is held in the proper position, use a hex wrench to tighten #10-32 set screw.
- For permanent applications, a threadlocker or retaining compound is advised in conjunction with the set screw.

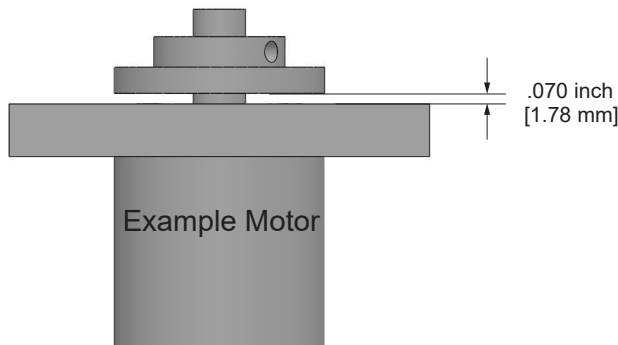

Example 1: Exposed rotor hub

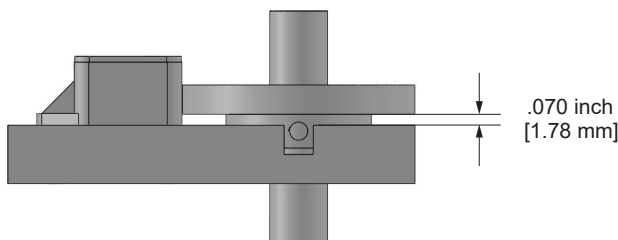
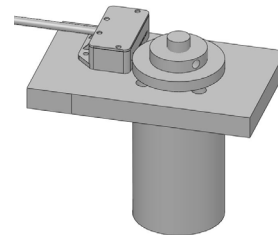

Example 2: Recessed rotor hub

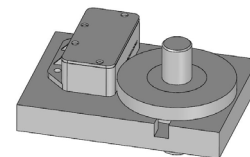

Images show two inch magnet rotor, but alignment targets hold true for all sizes.

Wiring

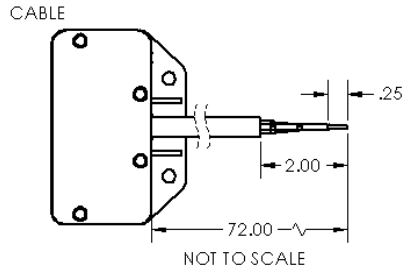

- 26 AWG
- 6 Conductor with Foil Shield and Drain
- Stranded Tinned Copper
- PVC Insulation
- Grey PVC Jacket
- UL Style 2464, CSA
- Temperature Rating: 105°C

Table 6.1

Differential Wiring	
Vcc	Red
Gnd	Black
Ch A	Yellow
Ch A-	Brown
Ch B	Green
Ch B-	Orange

Custom lengths and insulation materials available. Contact sales@phoenixamerica.com.

Connector Options (Single ended option depicted)

Molex Mini-Fit Jr. (Male)

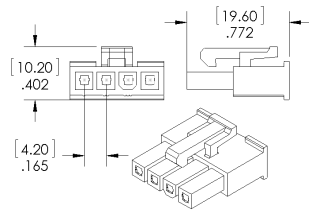

Molex Mini-Fit Jr. (Female)

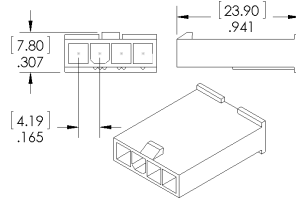

TE AmpModu MTE (Male)

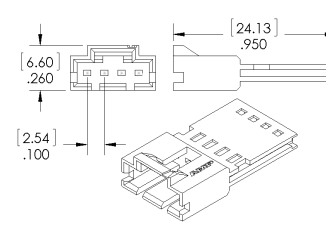

TE AmpModu MTE (Female)

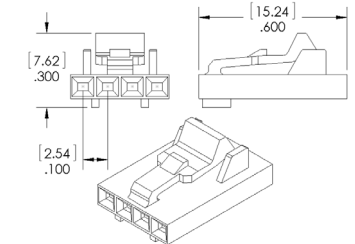

Need a different connector? Contact sales@phoenixamerica.com.

Part Number Description

N6 - 256 - 1000 - 24 - N - D - B - C - E - X

Series	PPR	Bore Size	Supply Voltage	Index	Output Type	Target Magnet Mounting	Wiring	Length (Meters)	Connector
N6	50	1000 1 in	05 5 V	N A,B Quadrature (default)	S Single-Ended D Differential (default)	B Aluminum Hub	C Cable	A .5 (19.685") B 0.914 (36") C 1 (39.370") D 2 (78.740") E 1.829 (72") (default)	X None (default) A1 TE AmpModu MTE (Male) A2 TE AmpModu MTE (Female) M1 Molex Mini-Fit Jr. (Male) M2 Molex Mini-Fit Jr. (Female) (default)
	64	1125 1 1/8 in							
	100	1182 30 mm	24 24 V (default)						
	128	1375 1 3/8 in							
	200	1500 1 1/2 in							
	256	1625 1 5/8 in							
	400	1875 1 7/8 in							
	500	2000 2 in							
	512	2125 2 1/8 in							
	640	2250 2 1/4 in							
	800	2375 2 3/8 in							
	1000	2500 2 1/2 in							
	1024	2750 2 3/4 in							
	1250								
	1600								
2000									
2048									
2500									
3200									
4000									
4096									
5000									

Example: N6-256-1000-24-N-D-B-C-E-X

Contact sales@phoenixamerica.com for additional resolutions and rotor configurations.